

EBSRAY PUMPS



SB Series Spraybars

Quality System

Quality
Endorsed
Company
ISO 9001
Lic 3332
Standards Australia

HEAD OFFICE AND WORKS

NZ LIMITED

AUSTRALIA

SB Series Spraybars



Fields of application

Ebsray manufactures a range of engineered Spraybars (Previously called "Continental" Spraybars) for all grades of bitumen, cutback, emulsion etc. which feature internal product recirculation operation for truck or trailer mounting in the toughest road spraying environments. The Spraybars are used in conjunction with Ebsray's range of purpose built heavy duty bitumen pumps - either internally tank mounted or external on tanker.

Assured Quality

Ebsray Spraybars are designed and manufactured to the highest quality standards. They have been developed in close cooperation with the Bitumen Industry to meet present and future operational needs.

All Design, Manufacturing, Assembly and Testing is carried out under Ebsray's third party accredited quality system, to ISO 9001.

Environmentally Engineered

Innovative design, precision machining, accurate assembly and testing ensures long service life and "leak free" operation. Ebsray Spraybars meet the stringent operational and environmental requirements for professional road spraying.

Range of Performance/Size

Flows	to 1500 l/min
Overall Lengths	to 8m (78 tap)
Centre Sections	16-Tap & 22-Tap
Turnups	4-Tap & 7-Tap
Extensions	3-Tap & 6-Tap

Custom manufacture for special requirements.

Fully Tested

Every Ebsray SB Series Spraybar, Tap, and Extension Module is Hydrostatically tested in the Works prior to dispatch to guarantee product integrity in accordance with the specifications.

Engineered in Australia



ISO 9001
Lic 3332
Standards
Australia

Quality
Endorsed
Company

Features

Constructional/Operational Features

- ✓ Recirculation system for liquid temperature maintenance.
- ✓ Environmental requirements met by eliminating the need to 'dump' product during cleaning operations.
- ✓ Cleaning procedures greatly simplified. No blowing required.
- ✓ Modular construction to suit a variety of configurations, bar lengths, capacities etc.

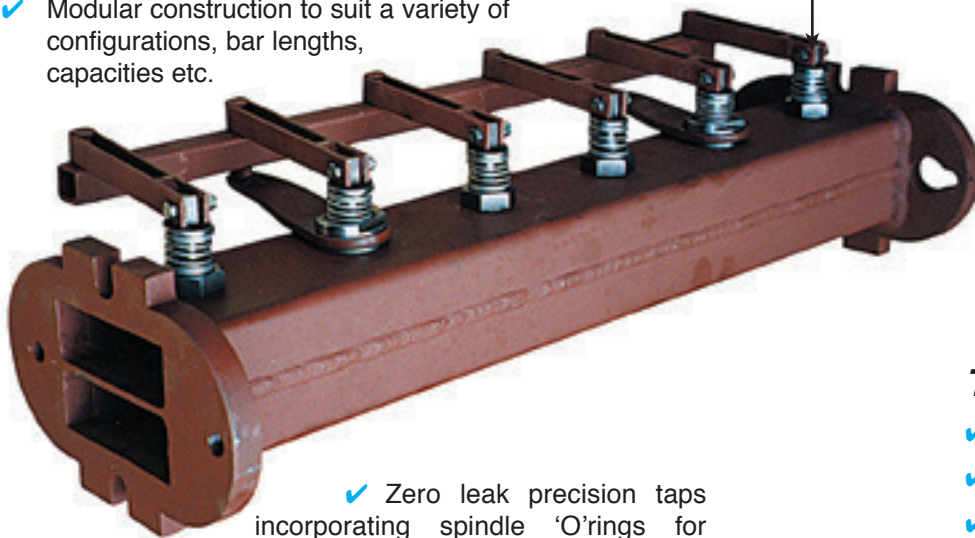

✓ Zero leak precision taps incorporating spindle 'O' rings for positive sealing, eliminating tap lock-up, and allowing low torque actuation.

- ✓ Accurate spraybar alignment with machined flanges and extension connections.
- ✓ Custom design (if required) to suit unique installations and applications.

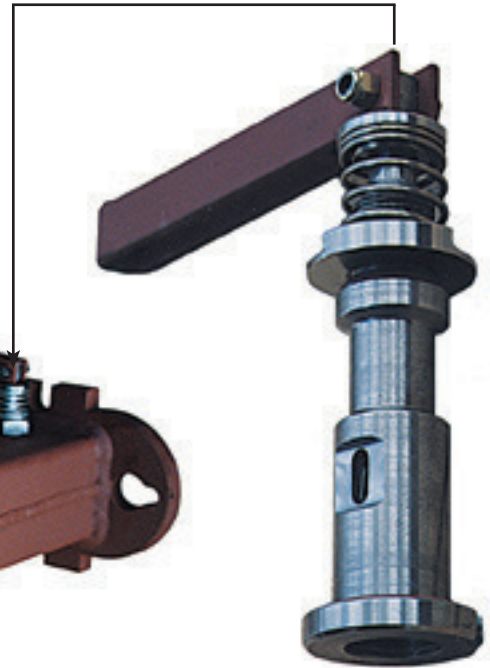

Taps

- ✓ "O" Ring design
- ✓ Reduced maintenance
- ✓ Increased life
- ✓ Low torque actuation
- ✓ Zero leak
- ✓ 'Lift handle' to isolate tap/s depending on spray pattern required

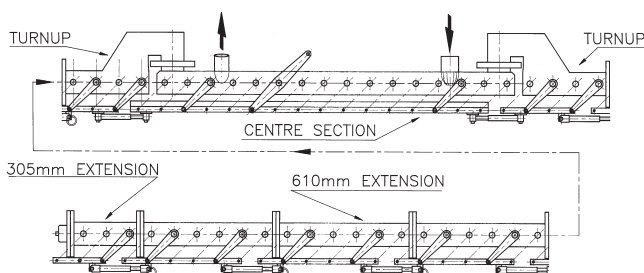

Modular Assembly

Spraybar lengths may be varied to suit application requirements. 6-tap (610 mm long) and 3-tap (305 mm long) modules allowing full recirculating capability may be simply bolted on or removed to adjust length.

Tap Isolation

Ebsray's tap linkage system allows quick and simple isolation/reconnection of single or multiple taps without the use of any tools.

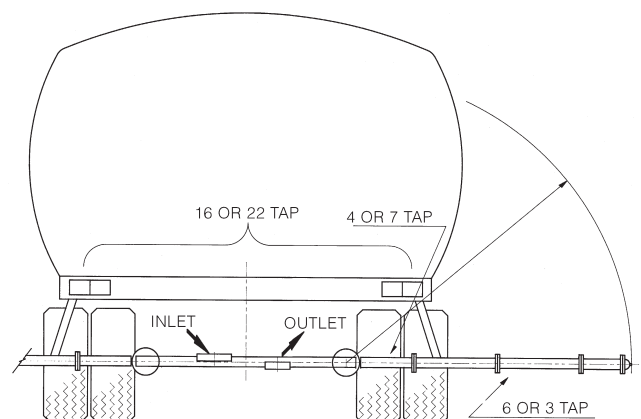

Bar

Folds into travelling position without disconnecting tap linkages.

Shear points designed to protect main bar and turnups in the event of extensions hitting an obstruction.

Ebsray Bitumen Pumps

Ebsray designs and manufactures a range of pumps suitable for numerous applications in the Bitumen / Asphalt industry.



Dependent on the application, EBSRAY can fulfil all your bitumen and associated product pumping requirements - from the high capacity L80 Transfer/Load out/Process pumps installed in refineries and processing plants handling flows in excess of 3000 l/m, through a complete range of MD/HD Series Internal Gear pumps (12mm to 150mm sizes) for all bitumen/asphalt plant pumping applications (Bitumen, Distillate, Kerosene, Polymers etc.)

In addition, EBSRAY V Series Sliding Vane pumps are widely used for transfer of Distillate,



Fuel oil, Lube oil and Kerosene etc. for process and refuelling requirements in the bitumen industry.

G Series - Tanker / Sprayer Pumps

A robust design particularly suitable for pumping bitumen, emulsions, cut back etc. in the toughest of environments i.e. Bitumen transfer, road sprayers, tanker duties.

Constructional Features

- ✓ Internal or external tank mounting
- ✓ Reversible rotation/configuration
- ✓ Helical cut gears
- ✓ Extra heavy duty build
- ✓ Simplicity of design

Materials of construction

Casing Cast iron

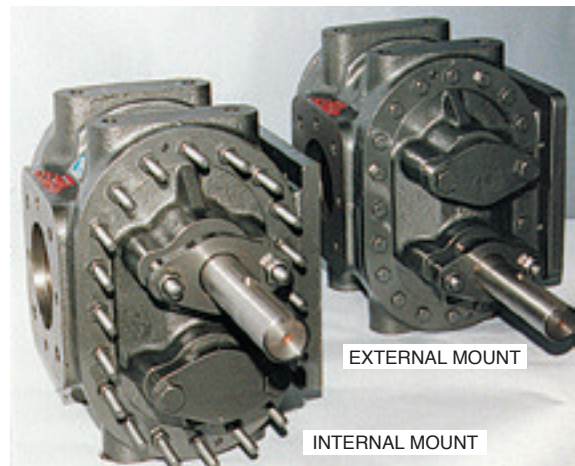

Rotors High tensile cast iron
Shaft Extra high tensile alloy steel

Special materials available upon request.

Range of Performance

Flows To 1600 l/min.
Differential Pressures To 2000 kPa
Viscosities To 1,000,000 cSt
Temperatures To 350°C



EBS-RAY PUMPS PTY. LIMITED

ACN 000 061 003

ISO 9001
Lic 3332
Standards
Australia

Head Office and Works
628 Pittwater Road
Brookvale NSW 2100
Australia.
Telephone: (02) 9905 0234
Fax: (02) 9938 3825
www.ebsraypumps.com.au

Branch Office Victoria
Phone: (03) 9706 7263
Fax: (03) 9706 7312
Branch Office Queensland
Phone: (07) 3260 7411
Fax: (07) 3260 7422

NOTE: All specifications and illustrations are typical only and subject to revision without notice. Certified data available upon request.



Wellington Head Office: 90 Sydney St, PO Box 38 720
Petone, Wellington, Tel: 64 4 568 4933, Fax: 64 4 568 4789
Email: sales@liquip.co.nz Website: www.liquip.co.nz

Publication #1463-02