

MK3 UNLOADING ARM TYPICAL ENVELOPE

ALL UNITS IN INCHES

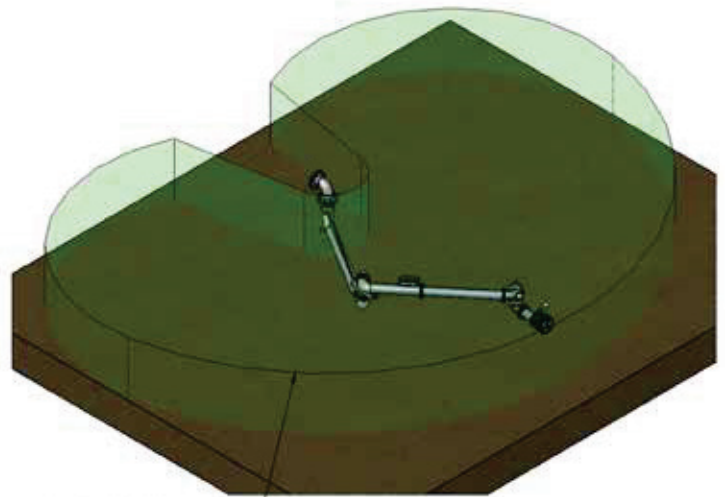

ENVELOPE SHOWS COUPLER REACH EXTREMITIES WITH SECONDARY ARM ±15°

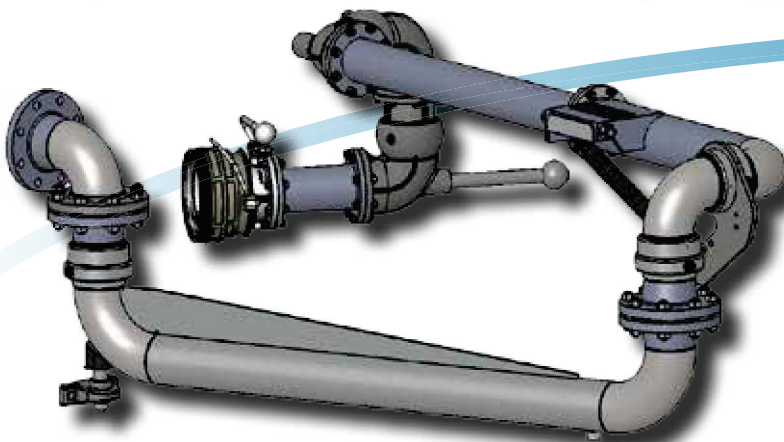
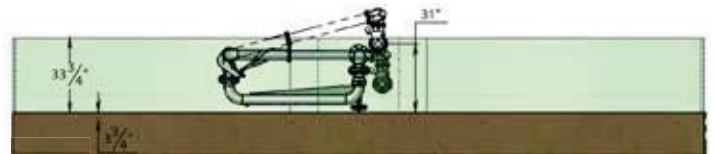
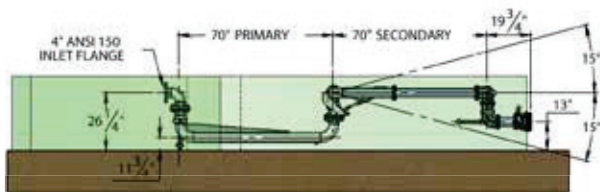

MK3

Low profile loading arm The benchmark for innovation

Key Features

- Eliminates the requirement for code hose and regular testing.
- Improves Site Safety by eliminating trip hazards.
- The low profile arm is also available in a self draining design to ensure complete tank drainage.
- Liquip use the latest in available design and manufacturing techniques to ensure that our arm designs work to their full potential, giving our customers the best possible solution for their investment, and consistent product quality.
- Available in a range of materials to suit various fluid transfer applications.

Another popular bottom loading design is the MK3 low profile loading and/or unloading arm.

The low profile arm can be used for gravity or pumped discharge of road and rail tankers, as well as for bottom loading. Also commonly used where there are space limitations overhead.

This makes the low profile unloader popular for large single compartment tanker loading and unloading, such as railcars, aviation bridging tankers and loading.