

LIQUIP HIGH PRESSURE HOSEREELS

DATA SHEET

**PART No's: HR12HP, HR18HP & HR24HP
FR12HP, FR18HP & FR24HP**

TITLE:	High pressure hose reel suitable for petroleum products.
PURPOSE:	The HP series of hose reels are a generation of reels for high pressure use and available with hand or hydraulic rewind and in different sizes. All enjoy the same robust construction – stiffened steel cheek plates, extremely sturdy thick wall manifold with added strength from steel inner drum, steel base frame and self aligning bearing. Flow area is equal to 38mm throughout. Sealing is by lip seal and all models incorporate an optional lock. Ball bearings look after rotation, with end thrust being taken care of by heavy-duty circlips and thrust washers. All components are easily replaced and manifold rubbing surfaces are nickel plated for long life.
OPERATION:	Just un-hook nozzle and dispense hose to the required location. To rewind hose a manual handle, or hydraulic motor is used. The hose nozzle storage can be fitted with interlocks to help prevent drive away accidents and product spills.
PERIODIC SERVICE:	Quarterly grease plumber block bearing. Annually remove & repack bearing on the inlet side of the reel.
VARIANTS:	Hose size – 25mm, 32mm, 38mm diameter. Rewind type – Manual or hydraulic. Drum width – 300mm, 450mm or 600mm Optional anti-rotation lock to prevent hose unravelling
MOUNTING:	4 x M10 bolts - see mounting footprint on following page
TECHNICAL DATA:	Pressure rated to 2100kPa
ASSOCIATED EQUIPMENT:	Aviation drum style hose reel: AHR250D Cartwheel type hosereels: AHR250 HR6-LM cartwheel with aluminium cheekplates Nozzles – AVN040 Nickel plated steel gooseneck with st steel inlet flange available Nickel plated gooseneck with 1 ¼" MBSPP thread available for aviation and water use. Rollers and guides.
OPTION:	Hot dip galvanised version. 1 ½" N/P FBSP entry flange. LPG version
MATERIALS OF CONSTRUCTION:	Mild steel cheek plates and drum. Polyurethane seals. Nitrile as option.

Overall dimensions shown on the drawing overleaf

LIQUIP

HYDRAULIC HOSE REELS

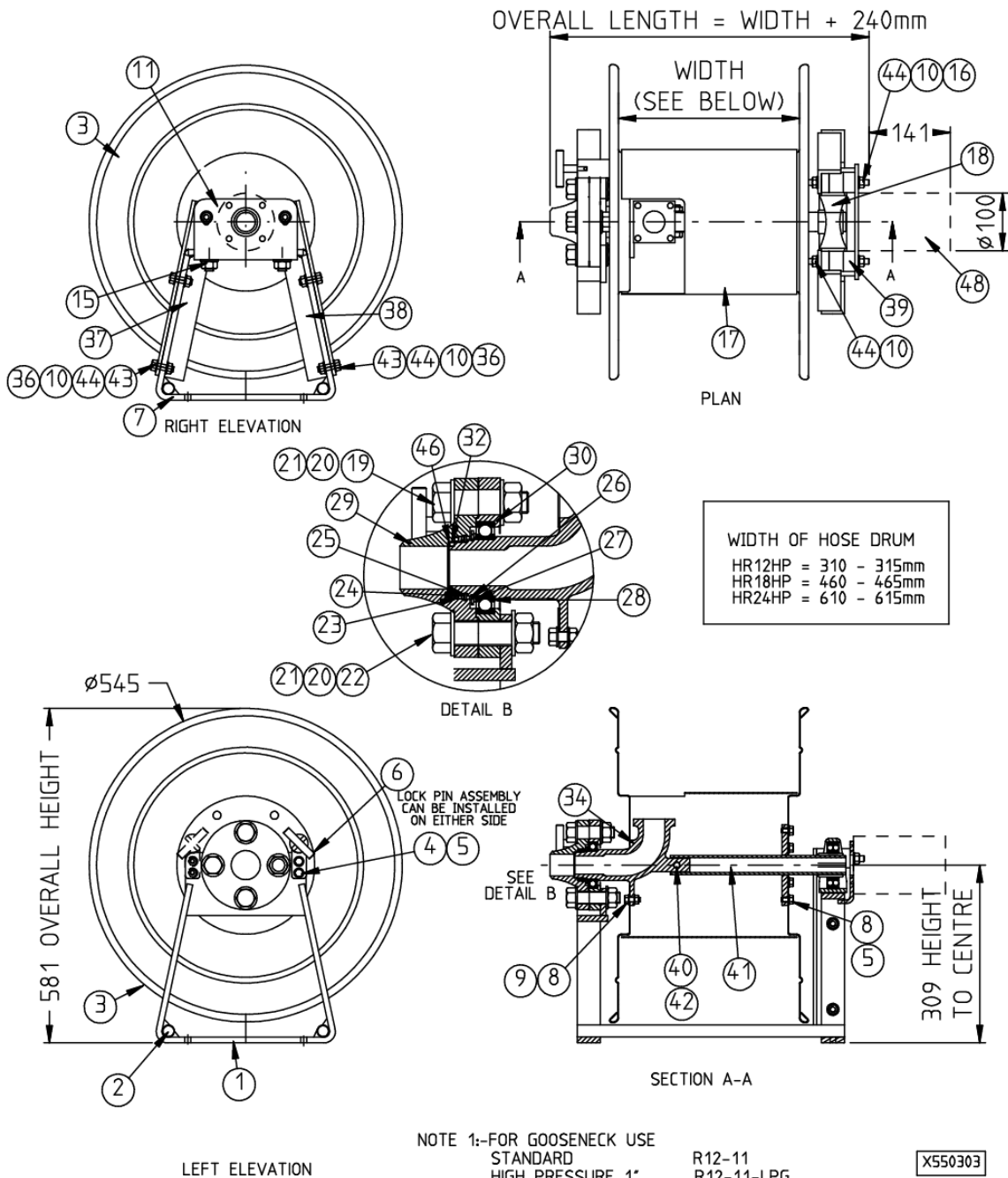

Sheet 1 of 2
Issue: C

METERS - VALVES - VENTS - MANHOLES - PUMPS - HOSEREELS - OVERFILL PROTECTION - LOADING ARMS - ELECTRONIC DIPSTICKS

LIQUIP

HYDRAULIC HOSE REELS

HYDRAULIC MOTOR:
 4 HOLE MOUNT, 7/8" - 14 TPI UNF SIDE PORTS,
 1" SHAFT, 199.8 CC/REV M300RPM.

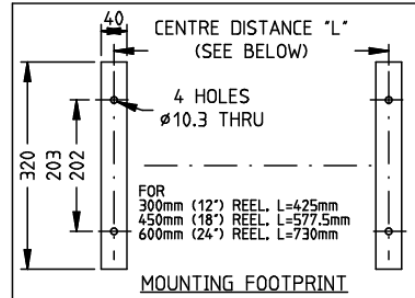

ITEM	PART No	PARTS THAT DIFFER ONLY SHOWN		DESCRIPTION	MATERIAL	QTY
		HR12HP	HR18HP			
1	R12HP-7	----	----	A FRAME AND BEARING MOUNTING BRKT ASSY	MILD STEEL	1
2	R12HP-33	R18HP-33	R24HP-33	A FRAME SPACER BAR	MILD STEEL	2
3	R12HP-8	----	----	HOSEREEL END SPINNING	MILD STEEL	2
4	0011	----	----	BOLT HEX HEAD	M/STEEL Z/P	3
5	0108	----	----	WASHER SPRING	M/STEEL Z/P	5
6	R12HP-10	----	----	LOCK PIN ASSEMBLY	MILD STEEL	1
7	R12HP-6	----	----	A FRAME BEARING SIDE	MILD STEEL	1
8	0012	----	----	BOLT HEX HEAD	M/STEEL Z/P	3
9	0149	----	----	NUT NYLOC	M/STEEL Z/P	3
10	0109	----	----	WASHER SPRING	M/STEEL Z/P	12
11	HR12HP-3	----	----	BRACKET MOUNTING MOTOR HYD	M/STEEL Z/P	1
12	4803	----	----	BOLT HEX HEAD	M/STEEL Z/P	2
13	R12-11	----	----	GOOSENECK ASSY 1 1/2" BSPT MALE (SEE NOTE 1)	MILD STEEL	1
14						
15	0154	----	----	NUT	M/STEEL Z/P	2
16	R12HP-14	----	----	MOTOR MOUNT RUBBER	RUBBER	2
17	R12-32	R18-2	R24-2	HOSE DRUM	MILD STEEL	1
18	4523	----	----	BEARING PILLOW BLOCK	HT/STEEL	1
19	4810	----	----	BOLT HEX HEAD	M/STEEL Z/P	1
20	4345	----	----	WASHER SPRING	M/STEEL Z/P	4
21	0799	----	----	NUT	M/STEEL Z/P	4
22	0876	----	----	BOLT HEX HEAD	M/STEEL Z/P	3
23	4516	----	----	SEAL U STYLE	POLYURETHANE	1
24	R12HP-9	----	----	RING BACKING SEAL	M/STEEL Z/P	1
25	4339	----	----	CIRCLIP INTERNAL	HT/STEEL	1
26	4338	----	----	CIRCLIP EXTERNAL	HT/STEEL	1
27	R12HP-22	----	----	RING BACKING BEARING	M/STEEL Z/P	1
28	4515	----	----	BEARING DEEP GROOVE BALL	HT/STEEL	1
29	R12HP-13	----	----	RETAINER SEAL	M/STEEL Z/P	1
30	R12HP-12	----	----	RETAINER BEARING	M/STEEL Z/P	1
31	0715	----	----	CAPSCREW	M/STEEL Z/P	2
32	R12-39	----	----	SHIM FOR MANIFOLD INLET ORING	ST STEEL	1
33						
34	R12-36	----	----	MANIFOLD	SG IRON	1
35	0150	----	----	NUT NYLOC	M/STEEL Z/P	4
36	0102	----	----	WASHER FLAT	M/STEEL Z/P	2
37	HR12HP-4L	----	----	BRACKET MOTOR SUPPORT LEFT HAND	MILD STEEL	1
38	HR12HP-4R	----	----	BRACKET MOTOR SUPPORT RIGHT HAND	MILD STEEL	1
39	HR12HP-18	----	----	SPACER MOTOR MOUNT	MILD STEEL	4
40	4879	----	----	BOLT HEX HEAD	M/STEEL Z/P	1
41	R12HP-11	R18HP-11	R24HP-11	BEARING SUPPORT PIPE	MILD STEEL	1
42	4981	----	----	NUT NYLOC	M/STEEL Z/P	1
43	0022	----	----	SETSCREW HEX HEAD	M/STEEL Z/P	4
44	0130	----	----	NUT	M/STEEL Z/P	4
45	2720	----	----	INSTRUCTION LEAFLET		1
46	4547	----	----	O-RING	VITON	1
47	4549	----	----	SEAL U STYLE	NITRILE	OPTIONAL
48	5437	----	----	HYDRAULIC MOTOR	STEEL	1

OPTIONAL REPLACEMENT * FOR ITEM 23

X550303

Sheet 2 of 2
Issue: C

METERS - VALVES - VENTS - MANHOLES - PUMPS - HOSEREELS - OVERFILL PROTECTION - LOADING ARMS - ELECTRONIC DIPSTICKS

LIQUIP

FRONT REWIND HOSE REELS

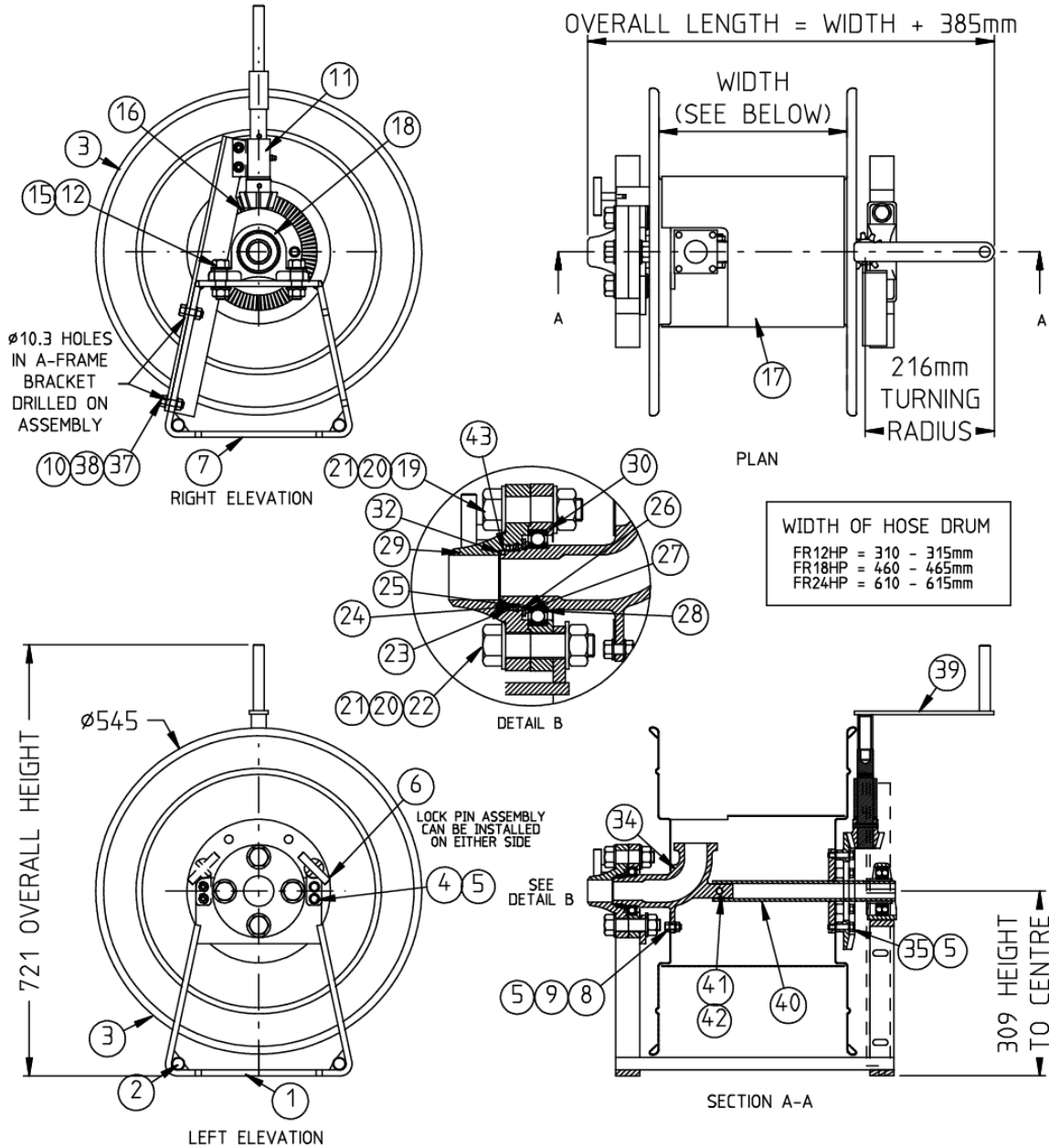

X450403
Sheet 1 of 2
Issue: D

METERS - VALVES - VENTS - MANHOLES - PUMPS - HOSEREELS - OVERFILL PROTECTION - LOADING ARMS - ELECTRONIC DIPSTICKS

LIQUIP

FRONT REWIND HOSE REELS

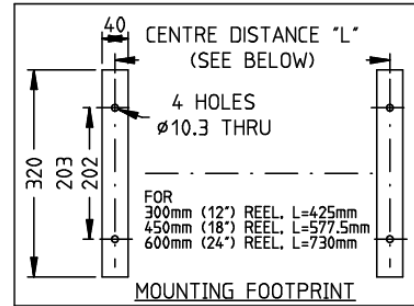

ITEM NO	PARTS THAT DIFFER ONLY SHOWN			DESCRIPTION	MATERIAL	QTY
	FR12HP	FR18HP	FR24HP			
1	R12HP-7	-----	-----	A FRAME AND BEARING MOUNTING BRKT ASSY	MILD STEEL	1
2	R12HP-33	R18HP-33	R24HP-33	A FRAME SPACER BAR	MILD STEEL	2
3	R12HP-8	-----	-----	HOSEREEL END SPINNING	MILD STEEL	2
4	0011	-----	-----	BOLT HEX HEAD	M/STEEL Z/P	3
5	0108	-----	-----	WASHER SPRING	M/STEEL Z/P	11
6	R12HP-10	-----	-----	LOCK PIN ASSEMBLY	MILD STEEL	1
7	R12HP-6	-----	-----	A FRAME BEARING SIDE	MILD STEEL	1
8	0012	-----	-----	BOLT HEX HEAD	M/STEEL Z/P	3
9	0149	-----	-----	NUT NYLOC	M/STEEL Z/P	3
10	0109	-----	-----	WASHER SPRING	M/STEEL Z/P	2
11	FR12HP-23	-----	-----	FRONT REWIND BRACKET ASSEMBLY	M/STEEL Z/P	1
12	4803	-----	-----	BOLT HEX HEAD	M/STEEL Z/P	2
13						
14	R12-11	-----	-----	GOOSENECK ASSY 1 1/2" BSPT MALE (SEE NOTE 1)	M/STEEL	1
15	0154	-----	-----	NUT NYLOC	M/STEEL Z/P	2
16	FR12-5	-----	-----	CROWN GEAR	ALUMINIUM	1
17	R12-32	R18-2	R24-2	HOSE DRUM	MILD STEEL	1
18	4523	-----	-----	BEARING PILLOW BLOCK	HT/STEEL	1
19	4810	-----	-----	BOLT HEX HEAD	M/STEEL Z/P	1
20	4345	-----	-----	WASHER SPRING	M/STEEL Z/P	4
21	0799	-----	-----	NUT	M/STEEL Z/P	4
22	0876	-----	-----	BOLT HEX HEAD	M/STEEL Z/P	3
23	4516	-----	-----	SEAL U STYLE	POLYURETHANE	1
24	R12HP-9	-----	-----	RING BACKING SEAL	M/STEEL Z/P	1
25	4339	-----	-----	CIRCLIP INTERNAL	HT/STEEL	1
26	4338	-----	-----	CIRCLIP EXTERNAL	HT/STEEL	1
27	R12HP-22	-----	-----	RING BACKING BEARING	M/STEEL Z/P	1
28	4515	-----	-----	BEARING DEEP GROOVE BALL	HT/STEEL	1
29	R12HP-13	-----	-----	RETAINER SEAL	M/STEEL Z/P	1
30	R12HP-12	-----	-----	RETAINER BEARING	M/STEEL Z/P	1
31						
32	R12-39	-----	-----	SHIM FOR MANIFOLD INLET ORING	ST STEEL	1
33						
34	R12-36	-----	-----	MANIFOLD	SG IRON	1
35	0015	-----	-----	SETScrew HEX HEAD	M/STEEL Z/P	6
36	0715	-----	-----	CAPSCREW	M/STEEL Z/P	2
37	0022	-----	-----	SETScrew HEX HEAD	M/STEEL Z/P	2
38	0130	-----	-----	NUT	M/STEEL Z/P	2
39	R12-26	-----	-----	REWIND HANDLE ASSEMBLY	MILD STEEL	1
40	R12HP-11	R18HP-11	R24HP-11	BEARING SUPPORT PIPE	MILD STEEL	1
41	4879	-----	-----	BOLT HEX HEAD	M/STEEL Z/P	1
42	4981	-----	-----	NUT NYLOC	M/STEEL Z/P	1
43	4547	-----	-----	O-RING	VITON	1
44	4549	-----	-----	SEAL U STYLE	NITRILE	OPTIONAL

OPTIONAL REPLACEMENT * FOR ITEM 23

X450403

Sheet 2 of 2
Issue: D

METERS - VALVES - VENTS - MANHOLES - PUMPS - HOSEREELS - OVERFILL PROTECTION - LOADING ARMS - ELECTRONIC DIPSTICKS