

LIQUIP HR150 HIGH PRESSURE HOSEREELS

DATA SHEET

**PART No's: HR150 &
HR150-LM**

TITLE:	High pressure hose reel suitable for petroleum products.
PURPOSE:	<p>The HP series of hose reels are a generation of reels for high pressure use and available with hand or hydraulic rewind and in different sizes. The HR150 has incorporated all the HP hosereel style features into the old style HR6. It has the same robust construction – stiffened cheek plates, extremely sturdy thick wall manifold with added strength from steel inner drum, steel base frame and self aligning bearing. Flow area is equal to 38mm throughout. Sealing is by lip seal and all models incorporate an optional lock. Ball bearings look after rotation, with end thrust being taken care of by heavy duty circlips and thrust washers. All components are easily replaced and manifold rubbing surfaces are nickel plated for long life.</p> <p>The HR150-LM replaces the old style HR6-LM cartwheel with aluminium cheekplates.</p>
OPERATION:	Just un-hook nozzle and dispense hose to the required location. To rewind the hose a hydraulic motor is used. The hose nozzle storage can be fitted with interlocks to help prevent drive away accidents and product spills.
PERIODIC SERVICE:	Quarterly grease plumber block bearing.
VARIANTS:	Hose size – 25mm, 32mm, and 38mm diameter.
MOUNTING:	4 x M10 bolts - see mounting footprint on following page
TECHNICAL DATA:	Pressure tested & rated to 2100kPa
ASSOCIATED EQUIPMENT:	HR150-LM standard model without motor. Aviation drum style hose reel: AHR250D Cartwheel type hosereels: AHR250 Nozzles – AVN040 Nickel plated steel gooseneck with st steel inlet flange available Nickel plated gooseneck with 1 ¼" MBSPP thread available for aviation and water use. Rollers and guides.
OPTION:	Hot dip galvanised version. 1 ½" N/P FBSP entry flange. LPG version
MATERIALS OF CONSTRUCTION:	Aluminium cheekplates, Mild steel drum & SG iron manifold. Polyurethane seals. Nitrile as option.

Overall dimensions shown on the drawing overleaf

LIQUIP

HR150 HIGH PRESSURE HOSEREELS

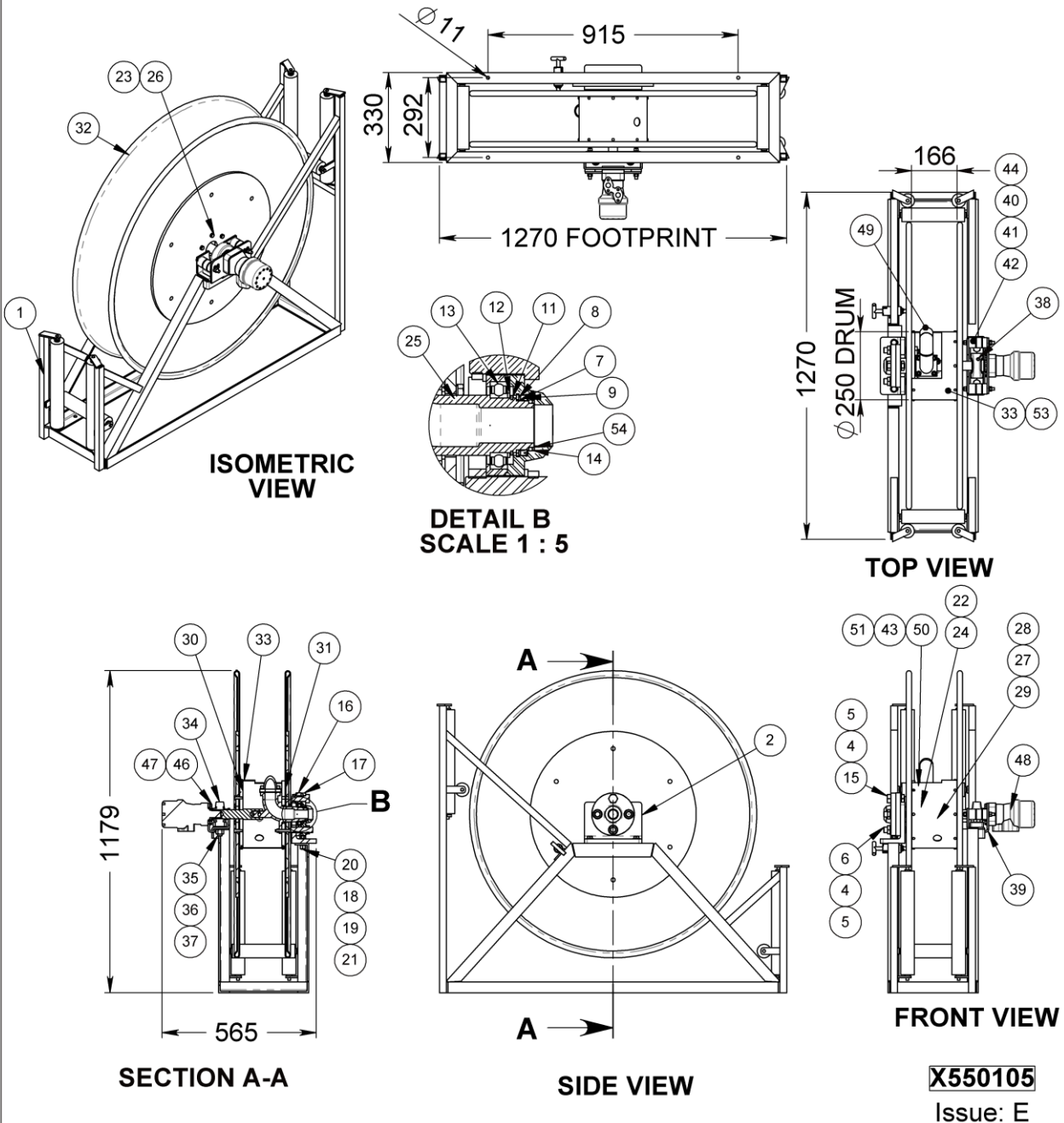

METERS - VALVES - VENTS - MANHOLES - PUMPS - HOSEREELS - OVERFILL PROTECTION - LOADING ARMS - ELECTRONIC DIPSTICKS



Wellington Head Office: 90 Sydney St, PO Box 38 720
Petone, Wellington, Tel: 64 4 568 4933, Fax: 64 4 568 4789
Email: sales@liquip.co.nz Website: www.liquip.co.nz

LIQUIP

HR150 HIGH PRESSURE HOSEREELS

ITEM NO.	PART NUMBER	DESCRIPTION	HR150	HR150-LM	MATERIAL
1	HR150-2	FRAME ASSEMBLY	1	1	STEEL
2	HR150-1	BRACKET INLET	1	1	STEEL
3	3362	LOCTITE	1	1	CYANOACRYLATE
4	5348	WASHER SPRING	4	4	Z/P STEEL
5	4396	NUT METRIC THIN	4	4	Z/P STEEL
6	6715	STUD METRIC	3	3	Z/P STEEL
7	R12HP-9	BACKING RING SEAL	1	1	MILD STEEL
8	4339	CIRCLIP INTERNAL	1	1	STEEL
9	4516	SEAL LIP HOSEREEL	1	1	URETHANE
10	7955	LOCTITE	1	1	CYANOACRYLATE
11	4338	CIRCLIP EXTERNAL METRIC	1	1	Z/P STEEL
12	R12HP-22	SPACER BEARING	1	1	STEEL
13	4515	BEARING BALL DEEP GROOVE	1	1	STEEL
14	4547	O-RING	1	1	VITON A
15	6707	SETSCREW METRIC	1	1	Z/P STEEL
16	R12HP-12	FLANGE SUPPORT BEARING	1	1	STEEL
17	R12HP-13	SEAL FLANGE	1	1	STEEL
18	4971	NUT METRIC	2	2	Z/P STEEL
19	5280	WASHER SPRING	2	2	Z/P STEEL
20	6720	SETSCREW METRIC	2	2	Z/P STEEL
21	5266	WASHER FLAT	2	2	Z/P STEEL
22	4395	NUT NYLOC	3	3	Z/P STEEL
23	6586	WASHER SPRING	9	9	ST STEEL
24	6656	BOLT METRIC	3	3	STAINLESS STEEL
25	R12-36	MANIFOLD	1	1	SG IRON
26	6585	SETSCREW METRIC	6	6	ST STEEL
27	4981	NUT NYLOC	1	1	Z/P STEEL
28	0813	WASHER FLAT	1	1	ST STEEL
29	6718	CAPSCREW METRIC	1	1	STEEL
30	HR150-9	BEARING SUPPORT TUBE	1	1	STEEL
31	HR150-10	DRUM SUPPORT	1	1	STEEL
32	HR150-12A	CHEEKPLATE & SUPPORT PLATE	2	2	ALUMINIUM
33	HR150-17	DRUM	1	1	2mm STEEL
34	4523	BEARING PILLOW BLOCK	1	1	S.G. IRON
35	6705	SETSCREW METRIC	2	2	Z/P STEEL
36	5359	WASHER SPRING	2	2	Z/P STEEL
37	1076	NUT METRIC	2	2	Z/P STEEL
38	5720	CAP/PLUG	1	1	PVC RED
39	HR12HP-3	BRACKET MOTOR MOUNT	1	1	STEEL
40	HR12HP-18	SPACER	2	2	STEEL
41	R12HP-14	RUBBER MOUNT	2	2	RUBBER/STEEL
42	HR150-4	SPACER FOR MOTOR MOUNT	2	2	MILD STEEL
43	0109	WASHER SPRING	8	8	Z/P STEEL
44	0130	NUT HEX	4	4	Z/P STEEL
45	3361	LOCTITE	1	-	CYANOACRYLATE
46	0020	SETSCREW HEX	4	-	Z/P STEEL
47	0102	WASHER FLAT	4	-	Z/P STEEL
48	1295	MOTOR HYDRAULIC	1	-	ASSY
49	R12-11	GOOSENECK 1 1/2"	1	1	STEEL
50	0719	CAPSCREW IMPERIAL	4	4	Z/P STEEL
51	0664	GASKET	1	1	NBR CORK
52	HR150-8	LOCK ASSY	1	1	STEEL
53	6714	HAMMER DRIVE SCREW	14	14	Z/P STEEL
54	R12-39	SHIM	1	1	304/316

X550105

Issue: E

METERS - VALVES - VENTS - MANHOLES - PUMPS - HOSEREELS - OVERFILL PROTECTION - LOADING ARMS - ELECTRONIC DIPSTICKS



Wellington Head Office: 90 Sydney St, PO Box 38 720

Petone, Wellington, Tel: 64 4 568 4933, Fax: 64 4 568 4789

Email: sales@liquip.co.nz Website: www.liquip.co.nz