

SERIES 16240

Side-Mount Vacuum Relief Vent



PROTECTOSEAL

- Sizes 2" (DN 50) through 14" (DN 350)
- Settings achieved by weight loading
- Reduces costly evaporation losses
- Leakage rate of less than 1 SCFH of air at 90% of set point
- Patented, FEP film "Air-Cushioned Seating"
- Low-leak pallet design - certified test reports
- Conforms with European ATEX Directive 94/9/EC
- Factory tested / certified for leakage and correct settings
- Available in Aluminum, Ductile Iron, Stainless Steel, Carbon Steel and Alloy C / C276

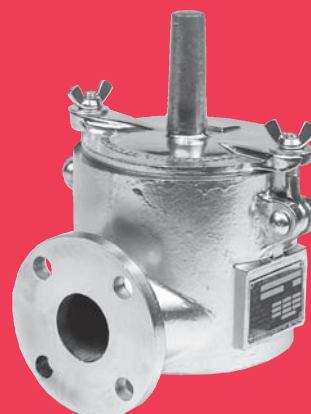

SERIES
16240

OBJECTIVE

The Protectoseal Series 16240, Vacuum Relief Vent provides vacuum relief to maintain tank's vapor space within safe operating parameters. Vent is designed to be mounted to a horizontally positioned pipe flange.

TECHNIQUE

A pallet in the vent housing retards air intake as the tank normally breathes in due to atmospheric temperature changes or due to emptying the tank. The pallet opens and closes to permit only the intake relief necessary to avoid tank damage under normal operating conditions.

Peripheral pallet assembly guides and center pallet stem guides insure proper alignment of pallet assembly on the seat and smooth lifting and reseating action.

Optimized Performance Vents™

Protectoseal's "Optimized Performance Vents" incorporate patented features that provide the optimum overall vent performance with regard to sealing, set point, flow and resealing (blow down).

SPECIAL FEATURES

Fast Inspection, Easy Maintenance. Design and light weight of entire unit permits easy, convenient handling for inspection and maintenance.

Maintains Accurate Pressure Settings. Set points are accurate to within +/- 3% across the entire range of available settings.

Air-Cushioned Seating. A flat, smooth diaphragm of FEP film is supported on both sides of an annular channel to form a floating air seal with the seat. An outer support rim assures proper seating.

Automatic Condensate Drainage. Self-draining housing body and drip rings keep condensate away from seating surfaces. Vent is protected from freezing, binding and clogging.

Low-Leakage. Vent leakage is no more than 1 SCFH at 90% of the set pressure. Pressure tested against leakage through castings and gasketed joints.

Sizes Available. Available in 2" (DN 50) through 14" (DN 350) sizes. Aluminum flanged to mate with 125# ANSI and DIN PN 16 flat face flanges. All other materials mate with 150# ANSI and DIN PN 16 raised face flanges. Other drilling patterns are also available upon special request.

PRO-FLOW III® Sizing and Selection Software.

Use PRO-FLOW III® to select the correct size unit for pressure and/or vacuum relief calculated in accordance with API 2000, ISO 28300, NFPA 30 and OSHA 1910.106.

CONSTRUCTION

A comprehensive range of materials is offered as shown in the chart below. Non-metallic (thermoplastic resin & FRP) construction available. Other materials and features can be furnished upon request.

Available Options.

- Alternate diaphragm materials
- Material certifications for castings
- Lower than standard minimum vacuum setting
- Higher than standard maximum vacuum setting
- Mounting connections added to vacuum port
- Steam jacketing available
- Electronic indication of vent opening
- FEP coating
- Kynar® coating (*Kynar® is a Registered Trademark of Arkema, Inc.*)
- Special cleaning & packaging for the storage of ultrapure liquids

Series	Housing	Pallet	Pallet Diaphragm	Weight Material
16240	Aluminum 356	Aluminum	FEP Film	Steel or Lead
C16240	Ductile Iron	316 S.S.	FEP Film	Steel or Lead
CS16240	Cast Steel	316 S.S.	FEP Film	Steel or Lead
F16240	316 S.S.	316 S.S.	FEP Film	S.S. or Lead
RE16240	Aluminum 356	316 S.S.	FEP Film	Steel or Lead
M16240	Alloy C	C276	FEP Film	C276 or Lead

Note: Aluminum flanged to mate with 125# ANSI and DIN PN 16 flat face flanges. All other materials mate with 150# ANSI and DIN PN 16 raised face flanges.

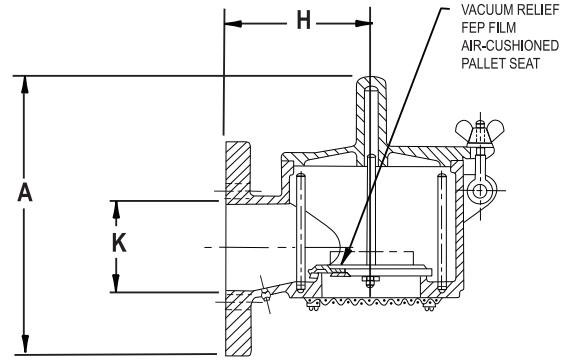
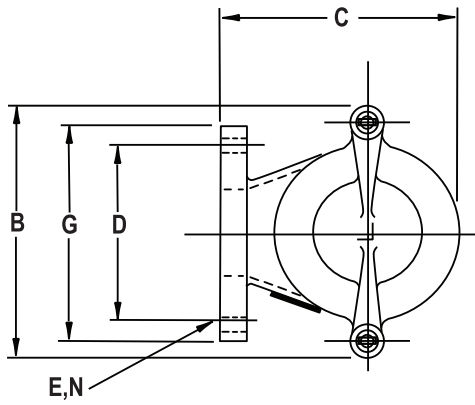

Dimensions shown are for reference only, contact Factory for certified drawings.

DIMENSIONS & ORDERING INFORMATION

Cat. No.*	Flange** K	Vent Size	Ht. A	Width B	Length C	H	B.C. D	Dia. G	Dia. E	Holes N
16240D2	2"	2"	12 $\frac{1}{4}$ "	9 $\frac{5}{8}$ "	9"	5 $\frac{1}{4}$ "	4 $\frac{3}{4}$ "	6	$\frac{3}{4}$ "	4
16240DN2	DN50	DN50	311mm	244mm	229mm	133mm	125mm	165mm	18mm	4
16240D3	3"	3"	13 $\frac{3}{4}$ "	9 $\frac{5}{8}$ "	10 $\frac{3}{8}$ "	5 $\frac{1}{2}$ "	6"	7 $\frac{1}{2}$ "	$\frac{3}{4}$ "	4
16240DN3	DN80	DN80	337mm	251mm	264mm	140mm	160mm	200mm	18mm	8
16240D4	4"	4"	15 $\frac{1}{4}$ "	9"	12 $\frac{1}{8}$ "	6 $\frac{1}{2}$ "	7 $\frac{1}{2}$ "	9"	$\frac{3}{4}$ "	8
16240DN4	DN100	DN100	387mm	229mm	308mm	165mm	180mm	220mm	18mm	8
16240D6	6"	6"	15 $\frac{3}{4}$ "	11"	15 $\frac{3}{8}$ "	8 $\frac{3}{8}$ "	9 $\frac{1}{2}$ "	11"	$\frac{7}{8}$ "	8
16240DN6	DN150	DN150	400mm	279mm	391mm	213mm	240mm	285mm	22mm	8
16246D8	8"	6"	16 $\frac{1}{4}$ "	13 $\frac{1}{2}$ "	15 $\frac{1}{2}$ "	8 $\frac{1}{2}$ "	11 $\frac{1}{4}$ "	13 $\frac{1}{2}$ "	$\frac{7}{8}$ "	8
16246DN8	DN200	DN150	413mm	343mm	394mm	216mm	295mm	340mm	22mm	12
16248D10	10"	8"	17 $\frac{1}{4}$ "	15 $\frac{1}{4}$ "	19 $\frac{1}{4}$ "	10 $\frac{1}{2}$ "	14 $\frac{1}{4}$ "	16"	1"	12
16248DN10	DN250	DN200	438mm	400mm	489mm	267mm	355mm	405mm	26mm	12
16250D12	12"	10"	19 $\frac{3}{4}$ "	18 $\frac{3}{4}$ "	21 $\frac{3}{4}$ "	12"	17"	19"	1"	12
16250DN12	DN300	DN250	502mm	476mm	552mm	305mm	410mm	460mm	26mm	12
16252D14	14"	12"	22 $\frac{1}{4}$ "	21"	21"	12"	18 $\frac{3}{4}$ "	21"	1 $\frac{1}{8}$ "	12
16252DN14	DN350	DN300	565mm	533mm	533mm	305mm	470mm	520mm	26mm	16

* Cat. No. designates Aluminum Housing & Pallets, please refer to chart on the reverse for other materials of construction. ** Note difference in vent size vs. mounting flange.

PRESSURE AND/OR VACUUM SETTINGS (Consult factory for settings outside of STANDARD range.)

Flange Size	STANDARD MINIMUM SETTINGS						STANDARD MAXIMUM SETTINGS					
	VACUUM						PRESSURE			VACUUM		
	Aluminum		Other Materials				All Materials			All Materials		
	oz./in. ²	in.W.C.	kPa	oz./in. ²	in.W.C.	kPa	oz./in. ²	in.W.C.	kPa	oz./in. ²	in.W.C.	kPa
2" / DN50	0.50	0.87	0.22	0.75	1.30	0.32	n/a	n/a	n/a	45.00	77.85	19.39
3" / DN80	0.50	0.87	0.22	0.75	1.30	0.32	n/a	n/a	n/a	36.00	62.28	15.51
4" / DN100	0.50	0.87	0.22	0.75	1.30	0.32	n/a	n/a	n/a	47.00	81.31	20.25
6" / DN150	0.50	0.87	0.22	0.75	1.30	0.32	n/a	n/a	n/a	32.00	55.36	13.79
8" / DN200	0.50	0.87	0.22	0.75	1.30	0.32	n/a	n/a	n/a	32.00	55.36	13.79
10" / DN250	0.50	0.87	0.22	0.75	1.30	0.32	n/a	n/a	n/a	27.00	46.71	11.63
12" / DN300	0.50	0.87	0.22	0.75	1.20	0.32	n/a	n/a	n/a	29.00	50.17	12.49
14" / DN350	0.50	0.87	0.22	0.75	1.20	0.32	n/a	n/a	n/a	23.00	39.79	9.91