

# SERIES 17800

## Pipe-Away Conservation Pressure Breather Vent



- Sizes 2" (DN 50) through 12" (DN 300)
- Settings achieved by weight loading
- Reduces costly evaporation losses
- Leakage rate of less than 1 SCFH of air at 90% of set point
- Patented, FEP film "Air-Cushioned Seating"
- Low-leak pallet design - certified test reports
- Conforms with European ATEX Directive 94/9/EC
- Factory tested / certified for leakage and correct settings
- Available in Aluminum, Ductile Iron, Stainless Steel, Carbon Steel and Alloy C / C276



SERIES  
17800

### OBJECTIVE

The Protectoseal Series 17800, Pipe-Away Pressure Conservation Vent is intended for use where pressure relief is required and the relieving vapors must be piped away and not emitted into the atmosphere. May also be used for in-line vacuum relief.

### TECHNIQUE

A pallet in the vent housing opens and closes permitting relief necessary, under normal working conditions, to avoid tank damage. A flanged side connection is provided for easy pipe-away of vapors, eliminating their emission into the atmosphere, and allowing compliance with applicable regulations.

Peripheral pallet assembly guides and center pallet stem guides insure proper alignment of pallet assembly on the seat and smooth lifting and reseating action.

### Optimized Performance Vents™

Protectoseal's "Optimized Performance Vents" incorporate patented features that provide the optimum overall vent performance with regard to sealing, set point, flow and resealing (blow down).

### SPECIAL FEATURES

**Fast Inspection, Easy Maintenance.** Design and light weight of entire unit permits easy, convenient handling for inspection and maintenance.

**Maintains Accurate Pressure Settings.** Set points are accurate to within +/- 3% across the entire range of available settings.

**Air-Cushioned Seating.** A flat, smooth diaphragm of FEP film is supported on both sides of an annular channel to form a floating air seal with the seat. An outer support rim assures proper seating.

**Automatic Condensate Drainage.** Self-draining housing body and drip rings keep condensate away from seating surfaces. Vent is protected from freezing, binding and clogging.

**Low-Leakage.** Vent leakage is no more than 1 SCFH at 90% of the set pressure. Pressure tested against leakage through castings and gasketed joints.

**Sizes Available.** Available in 2" (DN 50) through 12" (DN 300) sizes. Aluminum flanged to mate with 125# ANSI and DIN PN 16 flat face flanges. All other materials mate with 150# ANSI and DIN PN 16 raised face flanges. Other drilling patterns are also available upon special request.

### PRO-FLOW III® Sizing and Selection Software.

Use PRO-FLOW III® to select the correct size unit for pressure and vacuum relief calculated in accordance with API 2000, ISO 23800, NFPA 30 and OSHA 1910.106.

### CONSTRUCTION

A comprehensive range of materials is offered as shown in the chart below. Non-metallic (thermoplastic resin & FRP) construction available. Other materials and features can be furnished upon request.

### Available Options.

- Alternate diaphragm materials
- Material certifications for castings
- Lower than standard minimum pressure settings
- Steam jacketing available
- Manual or electronic indication of vent opening
- FEP coating
- Kynar® coating (*Kynar® is a Registered Trademark of Arkema, Inc.*)
- Special cleaning & packaging for the storage of ultrapure liquids

Series	Housing	Pallet	Pallet Diaphragm	Weight Material
17800	Aluminum 356	Aluminum	FEP Film	Steel or Lead
C17800	Ductile Iron	316 S.S.	FEP Film	Steel or Lead
CS17800	Cast Steel	316 S.S.	FEP Film	Steel or Lead
F17800	316 S.S.	316 S.S.	FEP Film	S.S. or Lead
RE17800	Aluminum 356	316 S.S.	FEP Film	Steel or Lead
M17800	Alloy C	C276	FEP Film	C276 or Lead

Note: Aluminum flanged to mate with 125# ANSI and DIN PN 16 flat face flanges. All other materials mate with 150# ANSI and DIN PN 16 raised face flanges.

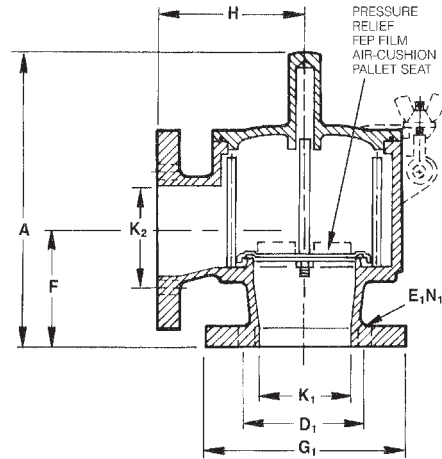
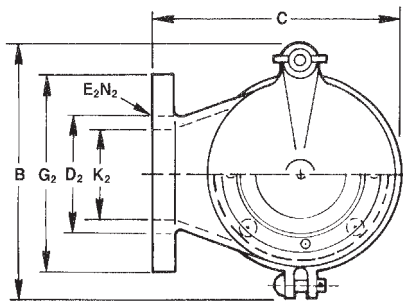

## DIMENSIONS & ORDERING INFORMATION

*Dimensions shown are for reference only, contact Factory for certified drawings*

Cat. No.*	Flange Size		Ht A	Width B	Length C	F	H	B.C.		Dia. G1	Dia. G2	Dia. E1	Dia. E2	Holes N1	Holes N2
	K1	K2						D1	D2						
17802D2	2"	2"	13"	9 <sup>7</sup> / <sub>8</sub> "	10"	3 <sup>7</sup> / <sub>8</sub> "	5 <sup>1</sup> / <sub>4</sub> "	4 <sup>3</sup> / <sub>4</sub> "	4 <sup>3</sup> / <sub>4</sub> "	6"	6"	3 <sup>3</sup> / <sub>4</sub> "	3 <sup>3</sup> / <sub>4</sub> "	4	4
17802DN2	DN50	DN50	330mm	251mm	254mm	98mm	133mm	125mm	125mm	165mm	165mm	18mm	18mm	4	4
17802D3	2"	3"	11"	9 <sup>7</sup> / <sub>8</sub> "	9 <sup>1</sup> / <sub>4</sub> "	4 <sup>3</sup> / <sub>8</sub> "	5 <sup>1</sup> / <sub>2</sub> "	4 <sup>3</sup> / <sub>4</sub> "	6"	6"	7 <sup>1</sup> / <sub>2</sub> "	3 <sup>3</sup> / <sub>4</sub> "	3 <sup>3</sup> / <sub>4</sub> "	4	4
17802DN3	DN50	DN80	279mm	251mm	235mm	111mm	140mm	125mm	160mm	165mm	200mm	18mm	18mm	4	8
17803D3	3"	3"	13"	9 <sup>7</sup> / <sub>8</sub> "	10 <sup>1</sup> / <sub>4</sub> "	4 <sup>1</sup> / <sub>4</sub> "	5 <sup>1</sup> / <sub>4</sub> "	6"	6"	7 <sup>1</sup> / <sub>2</sub> "	7 <sup>1</sup> / <sub>2</sub> "	3 <sup>3</sup> / <sub>4</sub> "	3 <sup>3</sup> / <sub>4</sub> "	4	4
17803DN3	DN80	DN80	330mm	244mm	260mm	108mm	140mm	160mm	160mm	200mm	200mm	18mm	18mm	8	8
17803D4	3"	4"	11"	9 <sup>7</sup> / <sub>8</sub> "	9 <sup>1</sup> / <sub>4</sub> "	5 <sup>1</sup> / <sub>4</sub> "	5 <sup>5</sup> / <sub>8</sub> "	6"	7 <sup>1</sup> / <sub>2</sub> "	7 <sup>1</sup> / <sub>2</sub> "	9"	3 <sup>3</sup> / <sub>4</sub> "	3 <sup>3</sup> / <sub>4</sub> "	4	8
17803DN4	DN80	DN100	279mm	244mm	235mm	133mm	143mm	160mm	180mm	200mm	220mm	18mm	18mm	8	8
17804D4	4"	4"	16 <sup>1</sup> / <sub>2</sub> "	10"	12 <sup>1</sup> / <sub>4</sub> "	6 <sup>3</sup> / <sub>8</sub> "	6 <sup>1</sup> / <sub>2</sub> "	7 <sup>1</sup> / <sub>2</sub> "	7 <sup>1</sup> / <sub>2</sub> "	9"	9"	3 <sup>3</sup> / <sub>4</sub> "	3 <sup>3</sup> / <sub>4</sub> "	8	8
17804DN4	DN100	DN100	419mm	254mm	311mm	156mm	165mm	180mm	180mm	220mm	220mm	18mm	18mm	8	8
17804D6	4"	6"	14 <sup>3</sup> / <sub>4</sub> "	11"	12 <sup>1</sup> / <sub>4</sub> "	6 <sup>3</sup> / <sub>8</sub> "	6 <sup>1</sup> / <sub>2</sub> "	7 <sup>1</sup> / <sub>2</sub> "	9 <sup>1</sup> / <sub>2</sub> "	9"	11"	3 <sup>3</sup> / <sub>4</sub> "	7 <sup>7</sup> / <sub>8</sub> "	8	8
17804DN6	DN100	DN150	375mm	279mm	311mm	162mm	165mm	180mm	240mm	220mm	285mm	18mm	22mm	8	8
17806D6	6"	6"	18"	11"	15 <sup>5</sup> / <sub>8</sub> "	7 <sup>3</sup> / <sub>4</sub> "	8 <sup>3</sup> / <sub>8</sub> "	9 <sup>1</sup> / <sub>2</sub> "	9 <sup>1</sup> / <sub>2</sub> "	11"	11"	7 <sup>7</sup> / <sub>8</sub> "	7 <sup>7</sup> / <sub>8</sub> "	8	8
17806DN6	DN150	DN150	457mm	279mm	391mm	197mm	213mm	240mm	240mm	285mm	285mm	22mm	22mm	8	8
17806D8	6"	8"	18"	13 <sup>1</sup> / <sub>2</sub> "	15 <sup>1</sup> / <sub>2</sub> "	8 <sup>1</sup> / <sub>2</sub> "	8 <sup>1</sup> / <sub>2</sub> "	9 <sup>1</sup> / <sub>2</sub> "	11 <sup>1</sup> / <sub>4</sub> "	11"	13 <sup>1</sup> / <sub>2</sub> "	7 <sup>7</sup> / <sub>8</sub> "	7 <sup>7</sup> / <sub>8</sub> "	8	8
17806DN8	DN150	DN200	457mm	343mm	394mm	216mm	216mm	240mm	295mm	285mm	340mm	22mm	22mm	8	12
17808D10	8"	10"	19 <sup>3</sup> / <sub>4</sub> "	16"	18 <sup>3</sup> / <sub>4</sub> "	10 <sup>1</sup> / <sub>2</sub> "	10 <sup>1</sup> / <sub>2</sub> "	11 <sup>1</sup> / <sub>4</sub> "	14 <sup>1</sup> / <sub>4</sub> "	13 <sup>1</sup> / <sub>2</sub> "	16"	7 <sup>7</sup> / <sub>8</sub> "	1"	8	12
17808DN10	DN200	DN250	502mm	406mm	476mm	267mm	267mm	295mm	355mm	340mm	405mm	22mm	26mm	12	12
17810D12	10"	12"	21 <sup>1</sup> / <sub>8</sub> "	19"	21 <sup>1</sup> / <sub>4</sub> "	11"	12"	14 <sup>1</sup> / <sub>4</sub> "	17"	16"	19"	1"	1"	12	12
17810DN12	DN250	DN300	537mm	483mm	552mm	279mm	305mm	355mm	410mm	405mm	460mm	26mm	26mm	12	12
17812D14	12"	14"	23 <sup>3</sup> / <sub>4</sub> "	21"	21"	12"	12"	17"	18 <sup>3</sup> / <sub>4</sub> "	19"	21"	1"	1 <sup>1</sup> / <sub>8</sub> "	12	12
17812DN14	DN300	DN350	603mm	533mm	533mm	305mm	305mm	410mm	470mm	460mm	520mm	26mm	26mm	12	16

\* Cat. No. designates Aluminum Housing & Pallets, please refer to chart on the reverse for other materials of construction.

## PRESSURE AND/OR VACUUM SETTINGS

*(Consult factory for settings outside of STANDARD range.)*

Flange Size	STANDARD MINIMUM SETTINGS						STANDARD MAXIMUM SETTINGS					
	PRESSURE ONLY						PRESSURE			VACUUM		
	Aluminum			Other Materials			All Materials			All Materials		
	oz./in. <sup>2</sup>	in.W.C.	kPa	oz./in. <sup>2</sup>	in.W.C.	kPa	oz./in. <sup>2</sup>	in.W.C.	kPa	oz./in. <sup>2</sup>	in.W.C.	kPa
2" x 2" / DN 50 x 50	0.50	0.87	0.22	0.75	1.30	0.32	45.00	77.85	19.39	N/A	N/A	N/A
2" x 3" / DN 50 x 80	0.50	0.87	0.22	0.75	1.30	0.32	17.00	29.41	7.32	N/A	N/A	N/A
3" x 3" / DN 80 x 80	0.50	0.87	0.22	0.75	1.30	0.32	36.00	62.28	15.51	N/A	N/A	N/A
3" x 4" / DN 80 x 100	0.50	0.87	0.22	0.75	1.30	0.32	23.00	39.79	9.91	N/A	N/A	N/A
4" x 4" / DN 100 x 100	0.50	0.87	0.22	0.75	1.30	0.32	47.00	81.31	20.25	N/A	N/A	N/A
4" x 6" / DN 100 x 150	0.50	0.87	0.22	0.75	1.30	0.32	31.00	53.63	13.36	N/A	N/A	N/A
6" x 6" / DN 150 x 150	0.50	0.87	0.22	0.75	1.30	0.32	32.00	55.36	13.79	N/A	N/A	N/A
6" x 8" / DN 150 x 200	0.50	0.87	0.22	0.75	1.30	0.32	32.00	55.36	13.79	N/A	N/A	N/A
8" x 10" / DN 200 x 250	0.50	0.87	0.22	0.75	1.30	0.32	27.00	46.71	11.63	N/A	N/A	N/A
10" x 12" / DN 250 x 300	0.50	0.87	0.22	0.75	1.30	0.32	29.00	50.17	12.49	N/A	N/A	N/A
12" x 14" / DN 300 x 350	0.50	0.87	0.22	0.75	1.30	0.32	23.00	39.79	9.91	N/A	N/A	N/A



Wellington Head Office: 90 Sydney St, PO Box 38 720  
 Petone, Wellington, Tel: 64 4 568 4933, Fax: 64 4 568 4789  
 Email: sales@liquip.co.nz Website: www.liquip.co.nz