

SAFETY
WITHOUT
COMPROMISE

SERIES 5200

Weatherhood Free Vent



- Sizes 2" (DN 50) through 24" (DN 600)
- Vapors vent to atmosphere
- Removable weatherhood protects tank opening
- Screen protects tank's interior from debris
- Lightweight design permits easy handling
- Easy to install and maintain
- Factory inspected prior to shipment
- Available in Aluminum, Stainless Steel and Carbon Steel

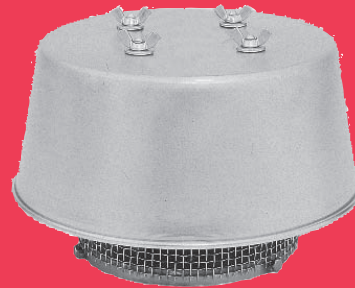

SERIES
5200

OBJECTIVE

The Protectoseal Series 5200 Free Vent provides open access to the tank's vapor space and provides pressure and vacuum venting. Flange connection mounts to tank's roof nozzle. Opening is protected by removable weatherhood. Protective mesh screen is also provided to minimize the possibility of debris entering the tank opening while allowing access to the tank's interior through roof nozzle for inspection, measurement, etc. The Series 5200 Free Vent is continuously open to the atmosphere.

SPECIAL FEATURES

Fast Inspection, Easy Maintenance. Design and light weight of entire unit permits easy, convenient handling for inspection and maintenance. Coarse mesh screen prevents entry of foreign matter into tank opening.

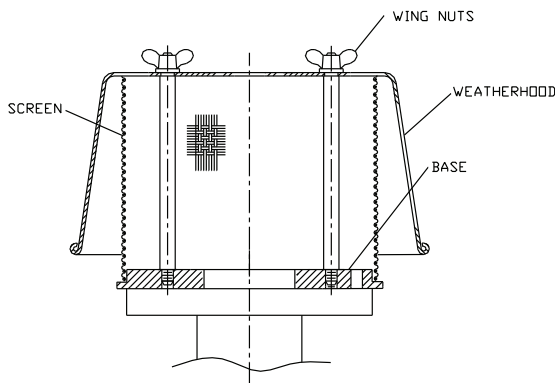

Sizes Available. 2" (DN 50) through 12" (DN 300) aluminum units flanged to mate with 125# ANSI and DIN PN 16 flat face flanges. All other materials mate with 150# ANSI and DIN PN 16 raised face flanges. 16" (DN 400) through 24" (DN600) units flanged to mate with applicable ANSI or API flat face flange connections.

CONSTRUCTION

A comprehensive range of materials is offered as shown in the chart below. Other materials and features can be furnished upon request.

Series	Size	Base Flange	Weather-Hood	Screen	Guides
5200D	2"-12"	Aluminum	Aluminum	Aluminum	316 S.S.
C5200D	2"-24"	Steel	Steel	Steel	316 S.S.
F5200D	2"-24"	316 S.S.	316 S.S.	316 S.S.	316 S.S.

2"-12" aluminum vents flanged to mate with 125# ANSI and DIN PN 16 flat face flanges. Steel and stainless steel units flanged to mate with 150# ANSI and DIN PN 16 raised face flanges. 16"-24" vents flanged to mate with applicable ANSI or API flat face flange connections.



DIMENSIONS & ORDERING INFORMATION

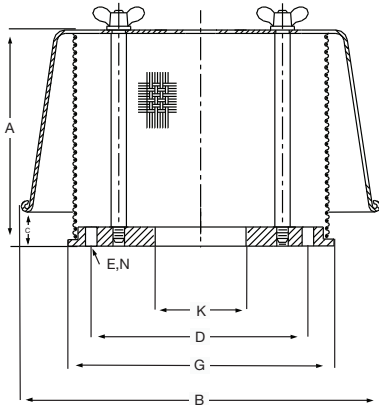

Cat. No.*	Pipe Size K	Ht. A	Width B	C	B.C. D	Dia. E	Dia. G	Holes N
5202D	2"	6¾"	8½"	1¼"	4¾"	¾"	6¾"	4
5202DND	DN50	171mm	216mm	32mm	125mm	18mm	171mm	4
5203D	3"	7⅝"	12¾"	2½"	6"	¾"	8¼"	4
5203DND	DN75	195mm	324mm	54mm	160mm	18mm	210mm	8
5204D	4"	7⅞"	12¾"	2⅝"	7½"	¾"	9¾"	8
5204DND	DN100	200mm	324mm	60mm	180mm	18mm	248mm	8
5206D	6"	10⅞"	15"	2⅞"	9½"	⅞"	11¾"	8
5206DND	DN150"	257mm	381mm	73mm	240mm	22mm	298mm	8
5208D	8"	11⅝"	17½"	3⅝"	11¾"	⅞"	14¼"	12
5208DND	DN200	295mm	445mm	86mm	295mm	22mm	362mm	12
5210D	10"	13"	23¼"	2¼"	14¼"	1"	16¾"	12
5210DND	DN250	330mm	591mm	57mm	355mm	226mm	425mm	12
5212D	12"	13¾"	25⅝"	2¾"	17"	1"	19¾"	12
5212DND	DN300	349mm	651mm	70mm	410mm	26mm	502mm	12
5216D	Consult Factory							
5216DND	Consult Factory							
5218D	Consult Factory							
5218DND	Consult Factory							
5220D	Consult Factory							
5220DND	Consult Factory							
5224D	Consult Factory							
5224DND	Consult Factory							

* Please refer to chart on the reverse for materials of construction.

ADDITIONAL PRODUCTS FROM PROTECTOSEAL

Series 18540



Pipe-Away Pressure Vacuum Relief Vent for applications that require hazardous vapors be processed into manifolded piping and not released into the atmosphere

Series 7800



Emergency Vent protects tanks against rupture or explosion resulting from excessive internal pressure caused by exposure to fires.

Series 4950



Vent Line / In-Line Parallel Plate Flame Arrester is designed for installation in open vent pipe or bleed lines from storage or processing tanks. Suitable for NEC Group D (IEC Group IIA) vapors

Series 830



Combination Pressure / Vacuum Relief Vent & Flame Arrester provides pressure and vacuum relief as well as protection from propagation of externally introduced flames. Suitable for NEC Group D (IEC Group IIA) vapors.