

# SERIES 53300

## Emergency Pressure Manhole Cover Vent

- Vents directly to atmosphere
- Sizes 16" (DN 400) through 24" (DN 600)
- Pressure setting achieved by weight loading
- Bonding wire prevents loss of cover
- Easy removal of cover allows for tank access
- Patented, FEP film "Air-Cushioned Seating"
- Low-leak pallet design - certified test reports
- Conforms with European ATEX Directive 94/9/EC
- Easy access manway facilitates inspection & repairs
- Available in Carbon Steel, Aluminum, Stainless Steel and FRP



SERIES  
53300

### OBJECTIVE

Protectoseal Series 53300 Emergency Pressure Manhole Cover Vents provide emergency pressure relief for storage tanks as well as convenient access for tank cleaning, inspection and repair work. They are designed for installation on the manhole opening of tank and provide a means of relieving large volumes of vapors, beyond the capacity of a normal operating vent, if an emergency fire involvement of the tank should occur. Series 53300 Manhole Covers do not provide vacuum relief. Vacuum relief must be supplied by operating vents such as Protectoseal Series 830, 8540, 6240, 16240 and 18540. Series 52500 Manway Cover Vents provide pressure and vacuum relief.

### TECHNIQUE

When positioned on the flanged seat, the Series 53300 Emergency Pressure Manhole Cover Vent provides an effective vapor-tight seal. Under emergency fire conditions, the cover opens fully to allow escape of vapors and prevent damage to the tank due to excessive pressure. The cover is tethered to the tank flange by a cable and must be manually repositioned after venting has occurred. The webs on the bottom of the cover insure proper guiding and positioning of the cover on the seat.

### SPECIAL FEATURES

**Fast Inspection, Easy Maintenance.** The design allows convenient access through the manhole opening for tank inspection and repair procedures. All parts are easily accessible for inspection, removal and replacement. A retaining cable prevents loss of cover.

**Maintains Accurate Pressure Settings.** Set points are accurate to within +/- 3% across the entire range of available pressure relief settings shown in the chart on the reverse. Set point accuracy is assured by stringent machining, assembly and test procedures. Higher settings are available upon special request, but may require longer lead times,

**Air-Cushioned Seating.** A flat, smooth diaphragm of FEP film is supported on both sides of an annular channel to form a floating air seal with the seat. An outer support rim assures proper seating.

**Low-Leak Covers.** Leakage on vent covers is no more than 1 SCFH at 90% of the set pressure.

**Sizes Available.** Available in 16" (DN 400) through 24" (DN 600) sizes. Flanged to mate with standard flanged 150# ANSI, API (20" or 24" only) or DIN PN 16 bolting specifications. Other drilling patterns are also available upon special request.

### PRO-FLOW III® Sizing and Selection Software.

Use PRO-FLOW III® Sizing and Selection Software to select the correct size unit for emergency pressure and vacuum relief calculated in accordance with API 2000, ISO 28300, NFPA 30 and OSHA 1910.106.

### CONSTRUCTION

A comprehensive range of materials is offered as shown in the chart below. Non-metallic (FRP) construction available. Other materials and features can be furnished upon request.

### Available Options.

- Alternate diaphragm materials
- Material certifications for castings
- FEP coating
- Kynar® coating (*Kynar® is a Registered Trademark of Arkema, Inc.*)

Series	Base Flange/Seat	Hood	Pallet	Diaphragm
AX53300	Steel/316 S.S.	Aluminum	Aluminum	FEP Film
AXC53300	Steel/316 S.S.	Steel	316 S.S.	FEP Film
AXCS53300	Steel/316 S.S.	Steel	Steel	FEP Film
AXF53300	316 S.S.	316 S.S.	316 S.S.	FEP Film

*Note: On AX, AXC, or AXCS Series, weights are steel or lead. On AXF Series, weights are stainless steel or lead.*

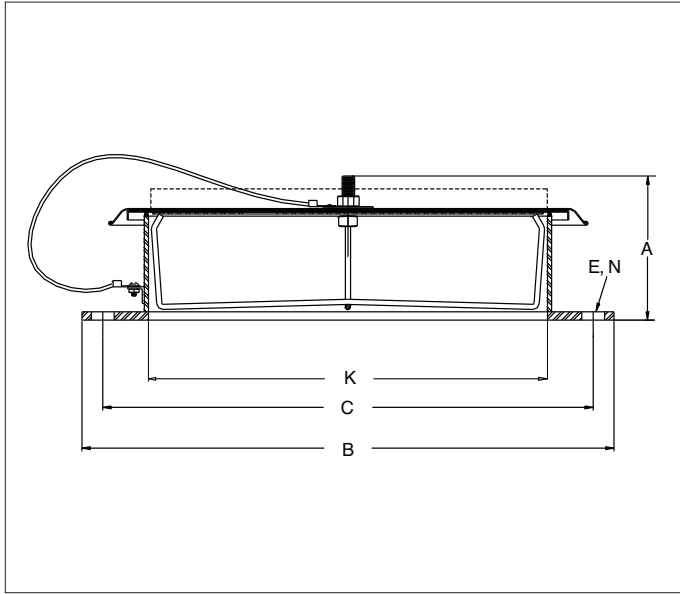

Dimensions shown are for reference only, contact Factory for certified drawings.

## DIMENSIONS & ORDERING INFORMATION

Cat. No.	Flange Size	I.D. K	Ht. A	Dia. B	B.C. C	Dia. E	Holes N
53316ASA	16"	15 1/4"	8 7/8"	23 1/2"	21 1/4"	1 1/8"	16
53316DN	DN 400	410mm	225mm	580mm	525mm	30mm	16
53318ASA	18"	15 1/4"	8 7/8"	25"	22 3/4"	1 1/4"	16
53318DN	DN 450	462mm	225mm	635mm	578mm	30mm	20
53320ASA	20"	20 1/2"	8 7/8"	27 1/2"	25"	1 1/4"	20
53320API	20"	20 1/2"	8 7/8"	26"	23 1/2"	3/4"	16
53320DN	DN 500	513mm	225mm	715mm	650mm	33mm	20
53324ASA	24"	24"	8 7/8"	32"	29 1/2"	1 3/8"	20
53324API	24"	24"	8 7/8"	30"	27 1/2"	3/4"	20
53324DN	DN 600	616mm	225mm	840mm	770mm	36mm	20

Add Prefix	Base Flange/Seat	Hood	Pallet	Diaphragm
AX	Steel/316 S.S.	Aluminum	Aluminum	FEP Film
AXC	Steel/316 S.S.	Steel	316 S.S.	FEP Film
AXCS	Steel/316 S.S.	Steel	Steel	FEP Film
AXF	316 S.S.	316 S.S.	316 S.S.	FEP Film

On AX, AXC, & AXCS Series, weights are steel or lead. On AXF Series, weights are S.S. or lead.

## PRESSURE AND/OR VACUUM SETTINGS (Consult factory for settings outside of STANDARD range.)

Series	Flange Size	STANDARD MINIMUM SETTINGS						STANDARD MAXIMUM SETTINGS*					
		Pressure			Vacuum			Pressure			Vacuum		
		oz./in. <sup>2</sup>	in. W.C.	kPa	oz./in. <sup>2</sup>	in. W.C.	kPa	oz./in. <sup>2</sup>	in. W.C.	kPa	oz./in. <sup>2</sup>	in. W.C.	kPa
AX53316	16"/DN 400	1.25	2.17	0.54	N/A	N/A	N/A	6.00	10.39	2.60	N/A	N/A	N/A
AXC, AXCS & AXF53316	16"/DN 400	1.73	3.00	0.75	N/A	N/A	N/A	6.00	10.39	2.60	N/A	N/A	N/A
AX53318	18"/DN 450	1.25	2.17	0.54	N/A	N/A	N/A	6.00	10.39	2.60	N/A	N/A	N/A
AXC, AXCS & AXF53318	18"/DN 450	1.73	3.00	0.75	N/A	N/A	N/A	6.00	10.39	2.60	N/A	N/A	N/A
AX53320	20"/DN 500	1.13	1.96	0.49	N/A	N/A	N/A	6.00	10.39	2.60	N/A	N/A	N/A
AXC, AXCS & AXF53320	20"/DN 500	1.73	3.00	0.75	N/A	N/A	N/A	6.00	10.39	2.60	N/A	N/A	N/A
AX53324	24"/DN 600	1.10	1.90	0.47	N/A	N/A	N/A	6.00	10.39	2.60	N/A	N/A	N/A
AXC, AXCS & AXF53324	24"/DN 600	1.73	3.00	0.75	N/A	N/A	N/A	6.00	10.39	2.60	N/A	N/A	N/A

\*CAUTION: The 6 oz. maximum setting requires a vent cover weight of approximately 70 lbs. on 16" & 18" units, 125 lbs. on 20" units and 175 lbs. on 24" units.

## ADDITIONAL PRODUCTS FROM PROTECTOSEAL

### Series 18540



Pipe-Away Pressure Vacuum Relief Vent for applications that require hazardous vapors be processed into manifolded piping and not released into the atmosphere.

### Series 7800



Emergency Vent protects tanks against rupture or explosion resulting from excessive internal pressure caused by exposure to fires.

### Series 4950



Vent Line / In-Line Parallel Plate Flame Arrester is designed for installation in open vent pipe or bleed lines from storage or processing tanks. Suitable for NEC Group D (IEC Group IIA) vapors.

### Series 830



Combination Pressure / Vacuum Relief Vent & Flame Arrester provides pressure and vacuum relief as well as protection from propagation of externally introduced flames. Suitable for NEC Group D (IEC Group IIA) vapors.