

# PUMPMASTER 45 AND 60 ACCESSORIES

## HOSE CONNECTION KIT

539 009

**539 009 Hose Connection kit for PM45 and PM60 oil pumps**  
Includes 1 m x 1/2" air hose (PN 248 018) with swivel elbow (PN 239 352), quick air coupler (PN 251 412), air nipple (PN 255 312), and 2 m x 3/4" oil hose (PN 362 302) with swivel elbow (PN 945 738).



## PUMP BRACKETS

360 121 - 360 132

**360 132 Wall bracket.** For PM45 and PM60 universal stub pumps.  
**360 121 Floor bracket.** For PM45 and PM60 universal stub pumps.



## BUNG ADAPTOR

360 006

**For use with PM45 10:1 pressure ratio pumps only**  
PM45 10:1 pumps are the only pumps with a 2" pump tube and therefore the only pumps that fit through 2" bung openings on drums and tanks. All other PM45 and PM60 pumps must be wall or floor mounted using an adequate bracket and suction accessories.

**360 006 Bung adaptor**  
For PM45 10:1 pumps only.



## SUCTION ACCESSORIES

367 016 Suction assembly for 205 l drums and lbs. For use with PM45 10:1 wall mounted universal stub pumps only.

It includes a 42 mm x 2 m suction tube with foot valve and 2 m x 3/4" hose.

**362 402 Suction hose 1.800 mm x 1-1/2" rubber connection hose.**  
1-1/2" BSP (M) connection elbow on one side and 1-1/2" (M) straight connection on the other.

**945 724 Connection adaptor, 1-1/2" BSP (MM).**

**945 737 Elbow, 1-1/2" BSP (FF).**

**609 104 Bung adaptor**  
Adaptor for fixing tube 736 771 to a 2" bung opening.

**896 498 Suction tube**  
1.000 x 1-1/2", 1-1/2" BSP (MF) connection threads.

**896 499 Suction tube**  
1.250 x 1-1/2", 1-1/2" BSP (MF) connection threads.

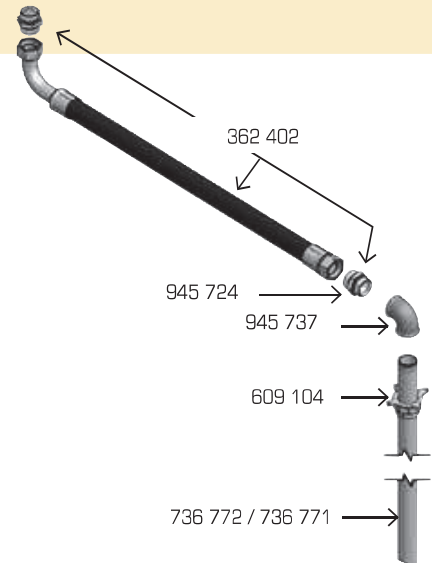

## PRESSURE RELEASE VALVES

609 007

Prevent damage caused by overpressure due to oil thermal expansion.  
**609 007 Pressure release valve.** Opening pressure approximate 60 bar.  
**609 008 Pressure release valve.** Opening pressure approximate 100 bar.

